

CIT Brains (Kid Size League)

Yasuo Hayashibara*, Hideaki Minakata*, Kiyoshi Irie*,
Katsuhiro Ichizawa*, Kousuke Machi*, Kazushiro Tanimoto*,
Kosuke Nohira*, Issei Tsuchihashi*, Yuka Yamada*, Toshiyuki Akitani*,
Yusuke Ito*, Daiki Maekawa*,
Shigechika Miki**, Yoshitaka Nishizaki ***, Kenji Kanemasu****,
Hajime Sakamoto*****

*Chiba Institute of Technology, 2-17-1 Tsudanuma, Narashino, Chiba, JAPAN

**Miki Seisakusyo Co, Ltd., 1-7-28 Ohno, Nishiyodogawa, Osaka, JAPAN

***Nishizaki Co, Ltd., 1-7-27 Ohno, Nishiyodogawa, Osaka, JAPAN

****Yosinori Industry, Ltd., 1-2-23 Owada, Nishiyodogawa, Osaka, JAPAN

*****Hajime Research Institute, Ltd., 1-7-28 Ohno, Nishiyodogawa, Osaka, JAPAN

yasuo.hayashibara@it-chiba.ac.jp

In this paper, we describe our robot system for the RoboCup soccer kid size humanoid league. The system we developed has high mobility, strong kicks, well-designed control system, position estimation by monocular camera and user-friendly interface. The robot can walk speedy and robustly. The maximum speed is approximately 0.4m/s. It also has a feedback system with gyro and acceleration sensors to prevent falls. The robot has two control boards. One is for walk and another is for image recognition, behavior determination and so on. The latter CPU board is a standard PICO-ITX embedded personal computer. Its operating system is Windows 7, so we can use Windows's useful tools. The robot detects the positions of landmarks by color-based image processing. A particle filter is employed to localize the robot in the soccer field fusing motion model and landmark observation. And, it has user-friendly interface to help strategy development. Our robot has wireless LAN interface to communicate outer PC. The robot sends data including measured positions and status of robot. The PC can store and analyze them to improve the rule of behavior.

1. Introduction

In this paper, we describe our system for the RoboCup soccer kid size humanoid league. Our robot is well-designed and controlled robustly. Last year, we got the second prize of 3on3 soccer and the third prize of technical challenge in RoboCup 2011 Turkey and the first prize of 3on3 soccer in RoboCup Japan Open 2011. Our team members were specialists from some technological areas. We integrate our

technologies for developing an intelligent humanoid robot. Hajime Research Institute developed the mechanism and control system of the robot. Chiba Institute of Technology developed computer system and overall intelligence such as image recognition and soccer algorithm. Remarkable topic is that the most of members are undergraduate students. Through this development, the professors try to make an educational and research platform robot system of intelligent humanoid. Almost all algorithm of behavior decision are programmed by the undergraduate student heuristically.

2. Overview of the System

The photograph of our robot is shown in Fig.1. Last year, we developed a new robot. The improved robot become taller and increases mechanical strength. The specification of the robot is indicated in Table 1. The overview of the control system is shown in Fig. 2. Our robot system consists of a USB camera, two computers, gyro and acceleration sensors, servo motors, batteries and some user interfaces such as switch and LED. Images are captured by the USB camera, and processed on the main CPU board to detect positions of ball, robots and landmarks. From the landmarks' positions, the robot estimates own position using a particle filter. From these data, the robot selects a next behavior. The behaviors which we can choose are not only just simple moving, but also complex task like following ball. Several pre-defined behaviors such as walk and kick are stored in the sub CPU, and a command to choose a behavior is sent to sub CPU via RS232C network. The sub CPU decodes and executes the command. It sometimes returns the status data to the main CPU. If the command is a kind of moving the body or checking a status, the sub CPU sends a command to servo motor via RS485 network. Each servo motor has own micro-controller to control motor and receive/send commands. Because all servo motors are daisy-chained, the command is sent to all motor. The command includes ID number, so the servo motor can identify the command to which is sent. The servo motor decodes and executes the command. The displacement angle is controlled in local motor unit. The sub CPU should not send commands at short intervals. Totally, this system is constructed as a well-designed hierarchic system. So, we can modify the system easily.

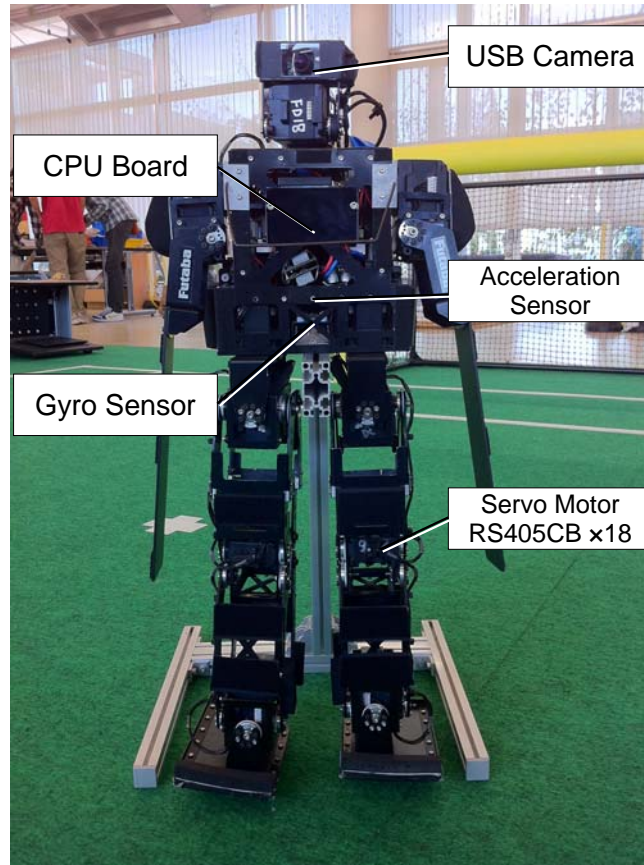

Fig.1 Structure of the Robot

Table 1 Specification of the Robot

Weight	4.0 kg (Including Batteries)
Height	600 mm
Velocity (Forward)	0.4 m/s (maximum)
Walking Directions	All direction and rotation (Select the angle, stride, period and so on)
CPU Board	COMMEL LP-170 (Intel Atom D525 1.8GHz) Sub: Hajime Robot HC5 (Renesas SH-2A/7211)
OS	Windows 7 Professional
Interface	Ether x 1, USB x 4, CF x 1, RS232C x 2, Sound In/Out , Digital I/O, etc
Servo Motor	Futaba RS405CB x 18
Battery	3S (11.1V, 5000mAh)

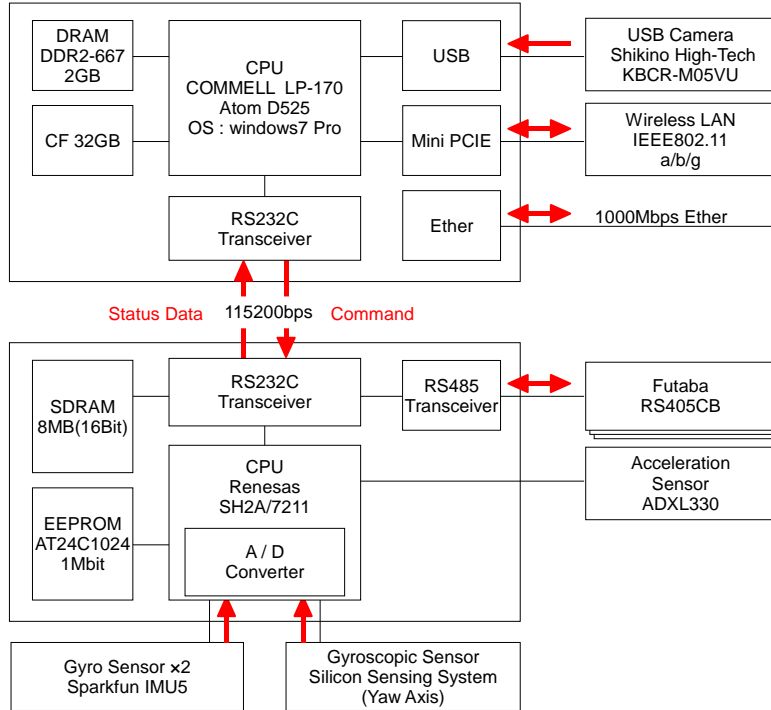

Fig.2 Overview of the Control System

3. Mobility

One of the significant features of our robot is the mobility. Through trial and error process, it can walk speedily and robustly. Its maximum speed is approximately 0.4m/s.

According to the command via RS232C, the robot activates many functions such as walking, kicking, returning the status data and so on. When the controller receives a command, it decodes and executes. If the command is related to servo motor control such as walk, motion generation and read status, the controller sends a command to servo motors via RS485. The controller also receives data from gyro and acceleration sensors via A/D converter. According to the data, the robot modifies the walking motion to prevent falls. The robot does not usually fall alone, however, in a soccer game it sometime fall when pushed by other robots. Even when the robot falls, it detects its posture and stand up smoothly.

We improved the leg structure by using a parallel mechanism. Fig. 4 shows an overview. The parallel mechanism generates vertical movement mechanically. Therefore, walking doesn't become unstable easily because it can lower the foot in parallel even if the motor has not synchronized completely while walking. In addition,

servo motors with a big torque is chosen to overcome the increased weight of the battery. Even if generation of heat of the motor was suppressed by these factors, and the robot walked for a long time, it came to keep stabilizing.

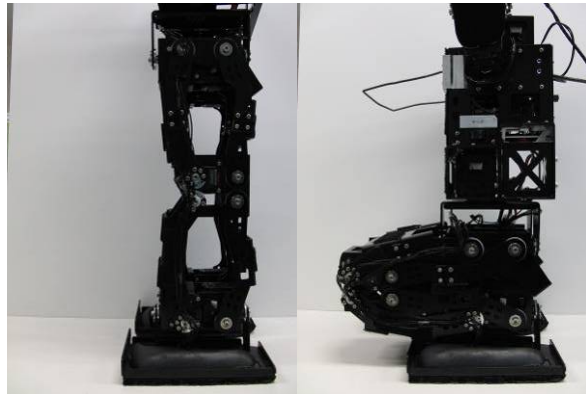

Fig.3 Parallel Mechanism of Foot

4. Computer System

One of significant feature of the robot is high computational capability. The robot is capable of processing VGA images 12 frames per a second. The CPU is Atom D525 and the operating system is Windows 7. It processes the image data, estimates the positions and determines the behavior. After these processes, it sends a command to sub CPU board for controlling the robot. Moreover, it was possible to develop easily by adopting Windows 7 that was accustomed to the operation and installing the development setting and to do.

5. Image Processing and Position Estimation

As mentioned above, the computer processes the image data of 12 frames per a second. The resolution of the camera can be selected from 1600x1200, 640x480, 320x240, and 160x120. Before this image processing, we should input the table of the color. We made an interface to input the value smoothly. The operator can change the value on GUI interface and check the effectiveness of the values immediately.

By measured positions of landmark, the position of the robot is estimated. We apply a particle filter to fuse the motion model and landmark observation. Goals and poles and white lines on the field are used as landmarks.

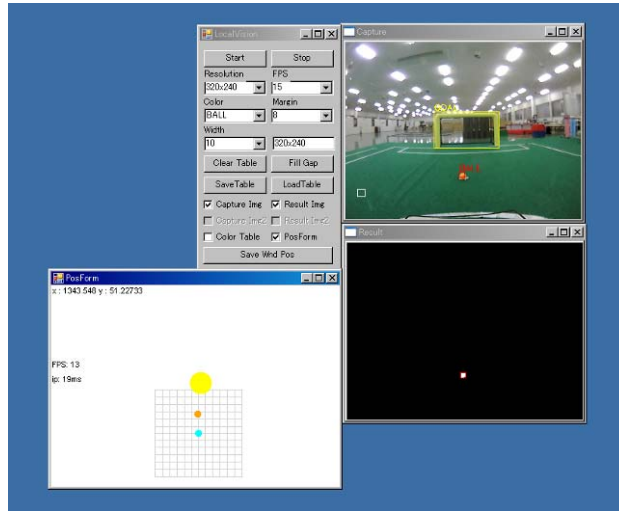

Fig.4 Graphic User Interface of Class Library
"Local Vision"

6. Strategy Development Environment

We develop a user-friendly interface for strategy development environment. The programmer can check many kind of thing in this interface. This interface is provided as following.

[output]

- 1) simple command to sub CPU (the command can also generate by mouse and keyboard)
- 2) table of color (Its effectiveness can be checked immediately)
- 3) program name like forward and keeper (It select the program in robot)own goal color and marker color

[input]

- 1) image data (It is possible to display the result of image processing)
- 2) detect and estimate positions (It is indicated graphically and saved in storage.)
- 3) command to sub CPU (We can check the algorism)
- 4) message (If the programmer want to know the robot status, he/she can insert the message in the program. It is also saved in storage)
- 5) color values (We use the YUV color value.)

These are example of input/output data. More data is interacted on this interface. Since the interface displays most of the significant status of the robot, the programmer can check the algorism and find problems easily.

7. Conclusion

In this paper we described our system. Our system has high mobility, strong kicks, well-designed control system, position estimation by one camera and user-friendly interface.